

KOA0022AX

PLUG-AND-SOCKET CONNECTOR LAYOUT

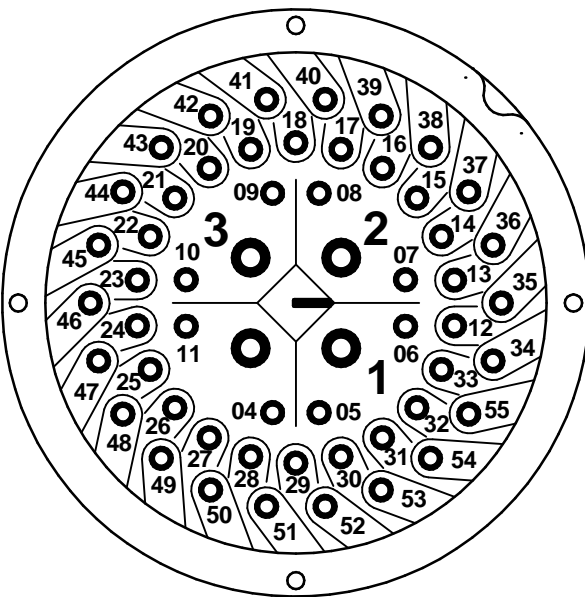

**LEGENDS:**

- |  |  |  |
|--|--|--|
| <b>M1</b> ELECTRIC MOTOR   | <b>ACTS</b> AUXILIARY CLOSE TORQUE SWITCH              | <b>CTS</b> CLOSE TORQUE SWITCH   |
| <b>R1</b> RELAY OUTPUT No1 (SETTABLE)                            | <b>AOTS</b> AUXILIARY OPEN TORQUE SWITCH               | <b>OTS</b> OPEN TORQUE SWITCH  |
| <b>R2</b> RELAY OUTPUT No2 (SETTABLE)                            | <b>ACLS</b> AUXILIARY CLOSE LIMIT SWITCH               | <b>CLS</b> CLOSE LIMIT SWITCH  |
| <b>R3</b> RELAY OUTPUT No3 (SETTABLE)                            | <b>AOLS</b> AUXILIARY OPEN LIMIT SWITCH                | <b>OLS</b> OPEN LIMIT SWITCH   |
| <b>R4</b> RELAY OUTPUT No4 (SETTABLE)                            | <b>IP1</b> VALVE MIDDLE TRAVEL POSITION SWITCH (No 1)  | <b>TRM</b> THERMAL PROTECTION DEVICE (MOTOR WIND.)                                 |
| <b>R5</b> RELAY OUTPUT No5 (SETTABLE)                            | <b>IP2</b> VALVE MIDDLE TRAVEL POSITION SWITCH (No 2)  | <b>HT</b> ANTI-CONDENSATION HEATER   |
| <b>R6</b> RELAY OUTPUT No6 (SETTABLE)                            | <b>IP3</b> VALVE MIDDLE TRAVEL POSITION SWITCH (No 3)  | <b>BLK</b> BLINKER SWITCH  |
| <b>R7</b> RELAY OUTPUT No7 (SETTABLE)                            | <b>IP4</b> VALVE MIDDLE TRAVEL POSITION SWITCH (No 4)  | <b>POT</b> POTENTIOMETER (VALVE POSITION SIGNAL)                                   |
| <b>R8</b> RELAY OUTPUT No8 (SETTABLE)                            | <b>CPT</b> CURRENT POSITION TRANSMITTER                | <b>CPT</b> CURRENT POSITION TRANSMITTER (VALVE POSITION SIGNAL)                    |
| <b>R9</b> RELAY OUTPUT No9 (SETTABLE)                            | <b>CTT</b> CURRENT TORQUE TRANSMITTER                  | <b>DSM</b> DIGITAL SWITCH MECHANISM (ELECTRONIC VALVE POSITION AND TORQUE SIGNALS) |
| <b>R10</b> RELAY OUTPUT No10 (SETTABLE)                          | <b>CPT.LP</b> CURRENT POSITION TRANSMITTER, LOOP POWER |  |
| <b>R11</b> RELAY OUTPUT No11 (SETTABLE)                          | <b>CTT.LP</b> CURRENT TORQUE TRANSMITTER, LOOP POWER   |  |
| <b>R12</b> RELAY OUTPUT No12 (SETTABLE)                          |  |  |
| <b>CS</b> CUSTOMER SUPPLY  |  |  |
| <b>BS</b> BACKUP SUPPLY  |  |  |
| <b>POSITIONER</b> POSITIONER IN/OUT ANALOG SIGNAL                |  |  |
| <b>POSITIONER.LP</b> POSITIONER IN/OUT ANALOG SIGNAL, LOOP POWER |  |  |
| <b>MONIT.</b> MONITOR RELAY                                      |  |  |
| <b>FIELDBUS</b> FIELDBUS CARD                                    |  |  |
| <b>REMOTE</b> REMOTE INPUT CARDS                                 |  |  |

**NOTES:**

1. THE TERMINAL PLAN SHOWS THE MULTI-TURN ELECTRIC ACTUATOR IN INTERMEDIATE POSITION, ACTUATOR CLOSES VALVE CLOCKWISE.
2. SEE ACTUATOR USER MANUAL AND DATASHEETS FOR TECHNICAL DATA, PARAMETERS AND DESCRIPTION OF THE ACTUATOR ELECTRIC AND ELECTRONIC EQUIPMENT.
3. IF THE ACTUATOR IS CONFIGURED TO BYPASS THE MOTOR PROTECTION THERMOSTAT (TRM), THE ACTUATOR WILL NO LONGER COMPLY WITH THE ESSENTIAL SAFETY REQUIREMENTS.
4. THE USER MUST FIT A CLASS 10 OVERLOAD RELAY. THE RELAY MUST BE SIZED ACCORDING TO THE OVERCURRENT PROT. DEVICE SETTING VALUE FOR THE MOTOR.
5. REFER TO THE MOTOR DATA SHEET FOR THIS VALUE. THE OVERLOAD RELAY MUST BE SIZED TO ENSURE THAT IT TRIPS WITHIN 10 SECONDS IN A FAULT CONDITION.
6. THE USER MUST COMPLETE A RISK ASSESSMENT AND IMPLEMENT WHATEVER MEASURES ARE REQUIRED TO ENSURE THAT THE RESULTANT SYSTEM COMPLIES WITH ALL APPLICABLE LEGISLATION.

PARAMETER	VALUE	DESCRIPTION
TYPE	K	MULTI-TURN ELECTRIC ACTUATOR, WITH CENTRONIK (DIGITAL SWITCH MECH.)
MAIN POWER SUPPLY	0	A.C. THREE PHASE
EXTRA CARD No 1	A	4 EXTRA RELAY CARD
EXTRA CARD No2	0	NO (WITHOUT)
MOTOR STARTER	0	REVERSIBLE CONTACTORS (STANDARD)
CUSTOMER SUPPLY & BLUETOOTH	2	24 VDC ±20% AT MAX. POW. OUTPUT 5W, AND BLUETOOTH CARD FOR REMOTE SETTING TOOL
BACKUP SUPPLY & HEATER	2	NO BACK UP SUPPLY, HEATER INCLUDED
EXTRA SWITCH	A	VISUAL INDICATOR DISC

ISSUE	DATE	ISSUE	DATE		
1	FIRST RELEASE	20-10-16	3	UPDATE NUMBER TERMINAL PLAN	09-05-18
2	ADD BLUETOOTH CARD SHEET 2	25-09-17	4	-	-

SHEET 1/2	DATE	SIGN.	TERMINAL PLAN
MADE BY	20-10-2016	JB	WD CKC-CKRC CTK., DSM, 3PH, REL, NOEX2, CTOR, CS24-BT, NOBK-HT, IMP
CHECKED	20-10-2016	JP	
APPROVED	20/10/2016	JP	

This drawing and the information it contains are property of Rotork Controls Limited, and they will not be reproduced or disclosed, in whole or in part, without the prior written consent of Rotork.

<b>CK</b> range	FORMAT	DRAWING N°
	A4	KOA0022AX - 3

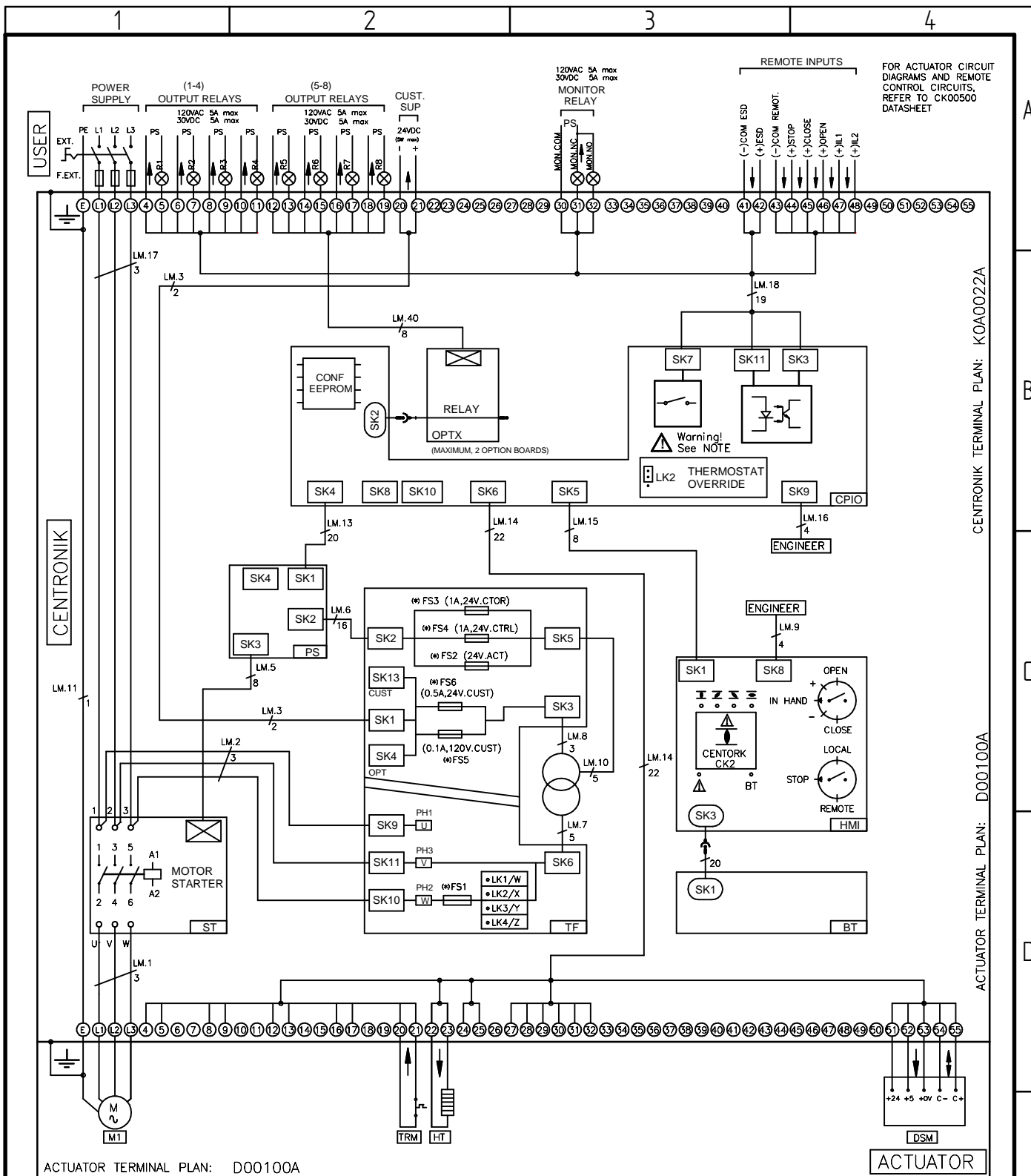

ACTUATOR TERMINAL PLAN: D00100A

**⚠ WARNING: REFER TO SAFE USE AND INSTALLATION MANUAL OR CK00500 DATASHEET FOR APPROVED FUSES.**

FS1: ACCORDING TO THE POWER SUPPLY VOLTAGE      110VAC/115VAC: FS1 (0,5 A)  
 ANY OTHER VOLTAGE: FS1 (0,25 A)

THE TERMINAL PLAN SHOWS THE MULTI-TURN ELECTRIC ACTUATOR IN INTERMEDIATE POSITION, ACTUATOR CLOSSES VALVE CLOCKWISE.  
 REFER TO SAFE USE AND INSTALLATION MANUAL AND DATASHEETS FOR TECH. DATA, PARAMETERS AND DESCRIPTION OF THE ACTUATOR ELECTRIC AND ELECTRONIC EQUIPMENT.  
 ACTUATORS WITH SOLID STATE STARTER (SSS), THE ACTUATOR MUST BE PROTECTED USING SUITABLE RATED HIGH SPEED SEMI-CONDUCTOR FUSES ON THE INCOMING SUPPLY.  
 IF THE ACTUATOR IS CONFIGURED TO BYPASS THE MOTOR PROTECTION THERMOSTAT (TRM), THE ACTUATOR WILL NO LONGER COMPLY WITH THE ESSENTIAL SAFETY REQUIREMENTS.  
 THE USER MUST CONDUCT A RISK ASSESSMENT, AND IMPLEMENT WHATEVER EXTRA SAFETY MEASURES ARE REQUIRED, TO ENSURE THAT THE RESULTANT SYSTEM COMPLIES WITH THE LOW VOLTAGE DIRECTIVE, AND ANY OTHER LEGISLATION IN FORCE AT THE INSTALLATION SITE.

**TRANSFORMER TAPPING OPTIONS**

TAP		PRIMARY TAP NOMINAL VOLTAGE (VAC 50/60Hz)		
		LV	EU	HV
LK1	W	110/115/120	380	460
LK2	X	220/230	400	480
LK3	Y	240	415	500
LK4	Z	n/a	440	600

ISSUE	DATE	ISSUE	DATE
1	FIRST RELEASE 20-10-16	3	--
2	ADD BLUETOOTH CARD SHEET 2 25-09-16	4	--

SHEET 2/2	DATE	SIGN.	WIRING DRAWING	This drawing and the information it contains are property of Rotork Controls Limited, and they will not be reproduced or disclosed, in whole or in part, without the prior written consent of Rotork.
MADE BY	20-10-2016	JB	WD CKC-CKRC CTK, DSM, 3PH, REL, NOEX2, CTOR, CS24-BT, NOBK-HT, IMP	
CHECKED	20-10-2016	JP		
APPROVED	20/10/2016	JP		

FORMAT	DRAWING N°
A4	KOA0022AX-3