

K0201220X

PLUG-AND-SOCKET CONNECTOR LAYOUT

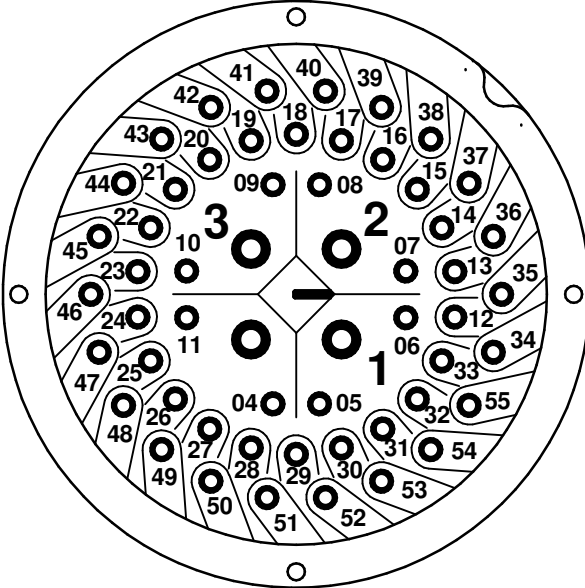

LEGENDS:

- | | | |
|--|--|--|
| M1 ELECTRIC MOTOR | ACTS AUXILIARY CLOSE TORQUE SWITCH | CTS CLOSE TORQUE SWITCH |
| R1 RELAY OUTPUT No1 (SETTABLE) | AOTS AUXILIARY OPEN TORQUE SWITCH | OTS OPEN TORQUE SWITCH |
| R2 RELAY OUTPUT No2 (SETTABLE) | ACLS AUXILIARY CLOSE LIMIT SWITCH | CLS CLOSE LIMIT SWITCH |
| R3 RELAY OUTPUT No3 (SETTABLE) | AOLS AUXILIARY OPEN LIMIT SWITCH | OLS OPEN LIMIT SWITCH |
| R4 RELAY OUTPUT No4 (SETTABLE) | IP1 VALVE MIDDLE TRAVEL POSITION SWITCH (No 1) | TRM THERMAL PROTECTION DEVICE (MOTOR WIND.) |
| R5 RELAY OUTPUT No5 (SETTABLE) | IP2 VALVE MIDDLE TRAVEL POSITION SWITCH (No 2) | HT ANTI-CONDENSATION HEATER |
| R6 RELAY OUTPUT No6 (SETTABLE) | IP3 VALVE MIDDLE TRAVEL POSITION SWITCH (No 3) | BLK BLINKER SWITCH |
| R7 RELAY OUTPUT No7 (SETTABLE) | IP4 VALVE MIDDLE TRAVEL POSITION SWITCH (No 4) | POT POTENTIOMETER (VALVE POSITION SIGNAL) |
| R8 RELAY OUTPUT No8 (SETTABLE) | CPT CURRENT POSITION TRANSMITTER | CPT CURRENT POSITION TRANSMITTER (VALVE POSITION SIGNAL) |
| R9 RELAY OUTPUT No9 (SETTABLE) | CTT CURRENT TORQUE TRANSMITTER | DSM DIGITAL SWITCH MECHANISM (ELECTRONIC VALVE POSITION AND TORQUE SIGNALS) |
| R10 RELAY OUTPUT No10 (SETTABLE) | CPT.LP CURRENT POSITION TRANSMITTER, LOOP POWER | |
| R11 RELAY OUTPUT No11 (SETTABLE) | CTT.LP CURRENT TORQUE TRANSMITTER, LOOP POWER | |
| R12 RELAY OUTPUT No12 (SETTABLE) | | |
| CS CUSTOMER SUPPLY | | |
| BS BACKUP SUPPLY | | |
| POSITIONER POSITIONER IN/OUT ANALOG SIGNAL | | |
| POSITIONER.LP POSITIONER IN/OUT ANALOG SIGNAL, LOOP POWER | | |
| MONIT. MONITOR RELAY | | |
| FIELDBUS FIELDBUS CARD | | |
| REMOTE REMOTE INPUT CARDS | | |

NOTES:

1. THE TERMINAL PLAN SHOWS THE MULTI-TURN ELECTRIC ACTUATOR IN INTERMEDIATE POSITION, ACTUATOR CLOSSES VALVE CLOCKWISE.
2. SEE ACTUATOR USER MANUAL AND DATASHEETS FOR TECHNICAL DATA, PARAMETERS AND DESCRIPTION OF THE ACTUATOR ELECTRIC AND ELECTRONIC EQUIPMENT.
3. IF THE ACTUATOR IS CONFIGURED TO BYPASS THE MOTOR PROTECTION THERMOSTAT (TRM), THE ACTUATOR WILL NO LONGER COMPLY WITH THE ESSENTIAL SAFETY REQUIREMENTS.
4. THE USER MUST FIT A CLASS 10 OVERLOAD RELAY. THE RELAY MUST BE SIZED ACCORDING TO THE OVERCURRENT PROT. DEVICE SETTING VALUE FOR THE MOTOR.
5. REFER TO THE MOTOR DATA SHEET FOR THIS VALUE. THE OVERLOAD RELAY MUST BE SIZED TO ENSURE THAT IT TRIPS WITHIN 10 SECONDS IN A FAULT CONDITION.
6. THE USER MUST COMPLETE A RISK ASSESSMENT AND IMPLEMENT WHATEVER MEASURES ARE REQUIRED TO ENSURE THAT THE RESULTANT SYSTEM COMPLIES WITH ALL APPLICABLE LEGISLATION.

PARAMETER	VALUE	DESCRIPTION
TYPE	K	MULTI-TURN ELECTRIC ACTUATOR, WITH CENTRONIK (DIGITAL SWITCH MECH.)
MAIN POWER SUPPLY	0	AC, THREE PHASE
EXTRA CARD No 1	2	PROFIBUS DP DUAL CHANNEL
EXTRA CARD No2	0	NO (WITHOUT)
MOTOR STARTER	1	SOLID STATE RELAY (THYRISTORS)
CUSTOMER SUPPLY & BLUETOOTH	2	24VDC±20% AT MAX.POW.OUTPUT 5W, AND BLUETOOTH CARD FOR REMOTE SETTING TOOL
BACKUP SUPPLY & HEATER	2	NO BACKUP SUPPLY, HEATER INCLUDED
EXTRA SWITCH	0	STANDARD, WITHOUT

ISSUE	DATE	ISSUE	DATE
1	FIRST RELEASE	08-05-20	3
2	-	-	4

SHEET 1/2	DATE	SIGN.	TERMINAL PLAN WD CKC-CKRE CTK, DSM, 3PH, PFB2, NOEX2, SSS, CS24-BT, NOBK-HT, NOEXT		FORMAT	DRAWING N°
MADE BY	08-05-2020	JB			A4	K0201220X - 1
CHECKED	08-05-2020	JP				
APPROVED	08-05-2020	JP				

This drawing and the information it contains are property of Rotork Controls Limited, and they will not be reproduced or disclosed, in whole or in part, without the prior written consent of Rotork.

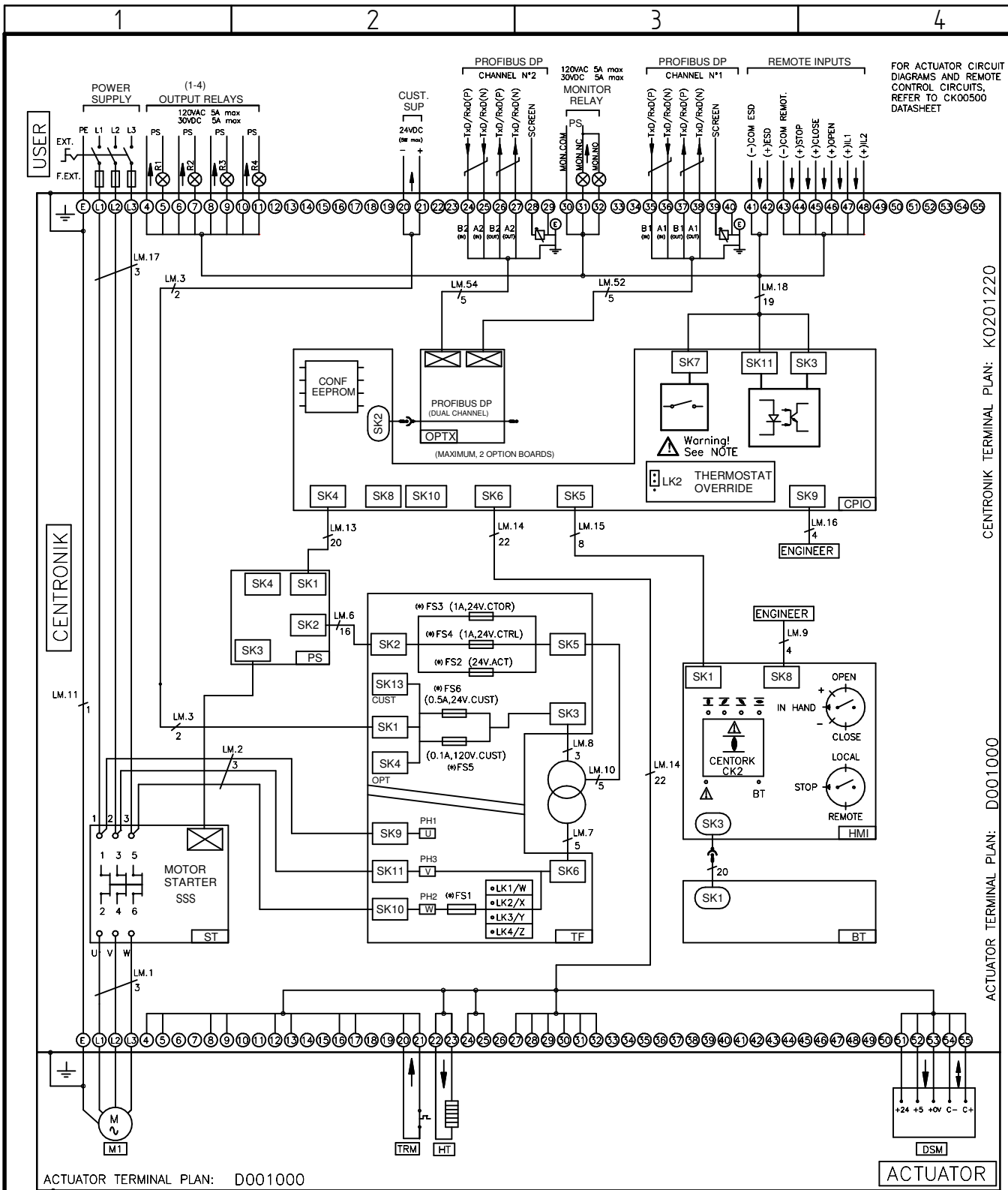

ACTUATOR TERMINAL PLAN: D001000

CENTRONIK TERMINAL PLAN: K0201220
ACTUATOR TERMINAL PLAN: D001000

WARNING: REFER TO SAFE USE AND INSTALLATION MANUAL OR CK00500 DATASHEET FOR APPROVED FUSES.

FS1: ACCORDING TO THE POWER SUPPLY VOLTAGE 110VAC/115VAC: FS1 (0,5 A)
 ANY OTHER VOLTAGE: FS1 (0,25 A)

THE TERMINAL PLAN SHOWS THE MULTI-TURN ELECTRIC ACTUATOR IN INTERMEDIATE POSITION, ACTUATOR CLOSES VALVE CLOCKWISE.
 REFER TO SAFE USE AND INSTALLATION MANUAL AND DATASHEETS FOR TECH. DATA, PARAMETERS AND DESCRIPTION OF THE ACTUATOR ELECTRIC AND ELECTRONIC EQUIPMENT.
 ACTUATORS WITH SOLID STATE STARTER (SSS), THE ACTUATOR MUST BE PROTECTED USING SUITABLE RATED HIGH SPEED SEMI-CONDUCTOR FUSES ON THE INCOMING SUPPLY.
 IF THE ACTUATOR IS CONFIGURED TO BYPASS THE MOTOR PROTECTION THERMOSTAT (TRM), THE ACTUATOR WILL NO LONGER COMPLY WITH THE ESSENTIAL SAFETY REQUIREMENTS.
 THE USER MUST CONDUCT A RISK ASSESSMENT, AND IMPLEMENT WHATEVER EXTRA SAFETY MEASURES ARE REQUIRED, TO ENSURE THAT THE RESULTANT SYSTEM COMPLIES WITH THE LOW VOLTAGE DIRECTIVE, AND ANY OTHER LEGISLATION IN FORCE AT THE INSTALLATION SITE.

TRANSFORMER TAPPING OPTIONS

TAP		PRIMARY TAP NOMINAL VOLTAGE (VAC 50/60Hz)		
		LV	EU	HV
LK1	W	110/115/120	380	460
LK2	X	220/230	400	480
LK3	Y	240	415	500
LK4	Z	n/a	440	600

ISSUE	DATE	ISSUE	DATE
1	FIRST RELEASE	08-05-20	3
2	-	-	4

SHEET 2/2	DATE	SIGN.	WIRING DRAWING	This drawing and the information it contains are property of Rotork Controls Limited, and they will not be reproduced or disclosed, in whole or in part, without the prior written consent of Rotork.
MADE BY	08-05-2020	JB	WD CKC-CKRC CTK., DSM, 3PH, PFB2, NOEX2, SSS, CS24-BT, NOBK-HT, NOEXT	
CHECKED	08-05-2020	JP		
APPROVED	08-05-2020	JP		



FORMAT: A4
 DRAWING N°: K0201220X-1