

M103000X

PLUG-AND-SOCKET CONNECTOR LAYOUT

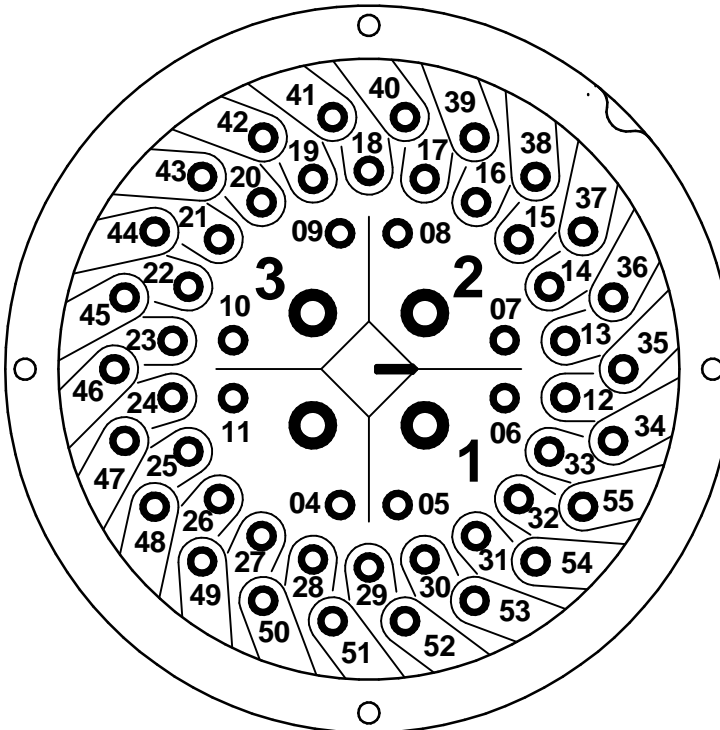

LEGENDS:

- M1** ELECTRIC MOTOR
- CTS** CLOSE TORQUE SWITCH
- OTS** OPEN TORQUE SWITCH
- CLS** CLOSE LIMIT SWITCH
- OLS** OPEN LIMIT SWITCH
- TRM** THERMAL PROTECTION DEVICE (MOTOR WIND).
- HT** ANTI-CONDENSATION HEATER
- BLK** BLINKER SWITCH
- POT** POTENTIOMETER (VALVE POSITION SIGNAL)
- CPT** CURRENT POSITION TRANSMITTER (VALVE POSITION SIGNAL)
- ACTS** AUXILIARY CLOSE TORQUE SWITCH
- AOTS** AUXILIARY OPEN TORQUE SWITCH
- ACLS** AUXILIARY CLOSE LIMIT SWITCH
- AOLS** AUXILIARY OPEN LIMIT SWITCH
- IP1** VALVE MIDDLE TRAVEL POSITION SWITCH(No 1)
- IP2** VALVE MIDDLE TRAVEL POSITION SWITCH(No 2)
- IP3** VALVE MIDDLE TRAVEL POSITION SWITCH(No 3)
- IP4** VALVE MIDDLE TRAVEL POSITION SWITCH(No 4)
- DSM** DIGITAL SWITCH MECHANISM(ELECTRONIC VALVE POSITION AND TORQUE SIGNALS)

NOTES:

1. THE TERMINAL PLAN SHOWS THE MULTI-TURN ELECTRIC ACTUATOR IN INTERMEDIATE POSITION, ACTUATOR CLOSES VALVE CLOCKWISE.
2. SEE ACTUATOR USER MANUAL AND DATASHEETS FOR TECHNICAL DATA, PARAMETERS AND DESCRIPTION OF THE ACTUATOR ELECTRIC AND ELECTRONIC EQUIPMENT.
3. IF THE ACTUATOR IS CONFIGURED TO BYPASS THE MOTOR PROTECTION THERMOSTAT (TRM), THE ACTUATOR WILL NO LONGER COMPLY WITH THE ESSENTIAL SAFETY REQUIREMENTS.
4. THE USER MUST FIT A CLASS 10 OVERLOAD RELAY. THE RELAY MUST BE SIZED ACCORDING TO THE OVERCURRENT PROT. DEVICE SETTING VALUE FOR THE MOTOR.
5. REFER TO THE MOTOR DATA SHEET FOR THIS VALUE. THE OVERLOAD RELAY MUST BE SIZED TO ENSURE THAT IT TRIPS WITHIN 10 SECONDS IN A FAULT CONDITION.
6. THE USER MUST COMPLETE A RISK ASSESSMENT AND IMPLEMENT WHATEVER MEASURES ARE REQUIRED TO ENSURE THAT THE RESULTANT SYSTEM COMPLIES WITH ALL APPLICABLE LEGISLATION.

PARAMETER	VALUE	DESCRIPTION
TYPE	M	MULTI-TURN ELECTRIC ACTUATOR, STANDARD UNIT (SYNCRSETI), MECHANICAL SWITCH MECH.
MAIN POWER SUPPLY	1	A.C. SINGLE PHASE
FEEDBACK ANALOG POS. SIG.	0	STANDARD: NOT INCLUDED(WITHOUT)
HEATER	3	ANTI-CONDENSATION HEATER, 110-120VAC
LIMIT SWITCHES	0	STANDARD: 1 OPEN AND 1 CLOSE LIMIT SWITCHES (DPOT)
TORQUE SWITCHES	0	STANDARD: 1 OPEN AND 1 CLOSE TORQUE SWITCHES (DPOT)
AUX. MIDDLE TRAVEL SWITCH	0	STANDARD: NOT INCLUDED (WITHOUT)

ISSUE	DATE	ISSUE	DATE
1	FIRST RELEASE 31-10-17	3	
2	MODIFY SHEET 2 NOTES 5 (3A BY 0.25A)	06-10-20	1

SHEET 1/2	DATE	SIGN.	TERMINAL PLAN WD CK-CKR STD, MSM, 1PH, NOCPT, HT115, LIM, TOR, NOIMP	This drawing and the information it contains are property of Rotork Controls Limited, and they will not be reproduced or disclosed, in whole or in part, without the prior written consent of Rotork.
MADE BY	31-10-2017	JB		
CHECKED	31-10-2017	JP		
APPROVED	31/10/2017	JP		

	FORMAT	DRAWING NO
	A4	M103000X - 2

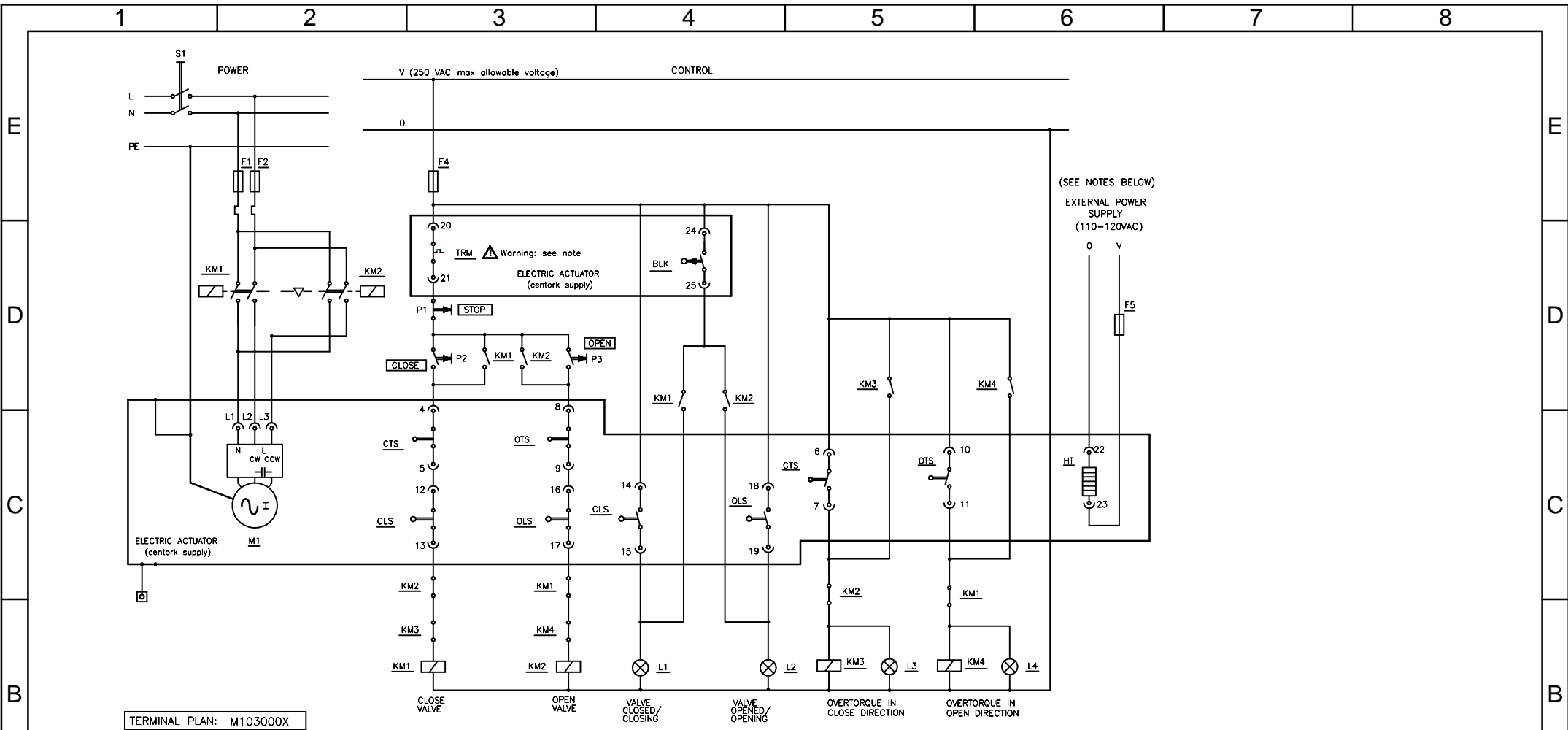

TERMINAL PLAN: M103000X

OPEN/CLOSE by limit switching

- CTS and OTS act as overload protection for the whole stroke, they interrupt the control circuit when reaching the actuator set tripping torque.
- OLS interrupts the control circuit when reaching the valve open limit set position.
- CLS interrupts the control circuit when reaching the valve close limit set position
- BLK gives information about valve movement.

OPEN by limit switching / CLOSE by torque switching

- CTS and OTS act as overload protection for the whole stroke, they interrupt the control circuit when reaching the actuator set tripping torque.
- OLS interrupts the control circuit when reaching the valve open limit set position.
- CTS interrupts the control circuit when closing (sealing) the valve. Set the close limit switch CLS shortly before reaching the closed end position
- BLK gives information about valve movement.

NOTES:

1. THE TERMINAL PLAN SHOWS THE ELECTRIC ACTUATOR IN INTERMEDIATE POSITION, ACTUATOR CLOSES VALVE CLOCKWISE
2. SEE ACTUATOR USER MANUAL FOR TECHNICAL DATA, PARAMETERS AND DESCRIPTION OF THE ACTUATOR ELECTRIC AND ELECTRONIC EQUIPMENT.
3. DPDT TORQUE(CTS, OTS, ACTS, AOTS) AND LIMIT MICROSWITCHES (CLS, OLS, ACLS, AOLS) HAVE 1NO+1NC CONTACTS, ONLY SAME POTENTIAL CAN BE CONNECTED THROUGH BOTH CIRCUITS. STANDARD 250VAC/5A, 24VDC 0.25A. GOLD CONTACT SWITCHE (LOW ENER.G. CIRCUITS) UNDER REQUEST
4. INTERMEDIATE POSITION SWITCHES, NO/NC CONTACT SETTABLE BY CAM (ACTUATOR)
5. EXTERNAL POWER SUPPLY FOR HEATER: HEATER MUST BE POWERED ACCORDING TO HEATER RATED VOLTAGE (SEE ACTUATOR ORDER FORM OR ORDER ACKNOWLEDGEMENT), A 250V 50mA QUICK BLOW FUSE MUST BE INSTALLED FOR 120V AND 240V RATED HEATERS
6. OPT ELECTRONIC POSITION TRANSMITTER: VOLTAGE/CURRENT 2, 3 AND 4 WIRES CONFIGURATIONS ARE POSSIBLE. CHECK PROPER TECHNICAL DATASHEET.
7. PRECISION POTENTIOMETER (POT): CHECK OHMIC VALUE
8. IF THE ACTUATOR IS CONFIGURED TO BYPASS THE MOTOR PROTECTION THERMOSTAT (TRM), THE ACTUATOR WILL NO LONGER COMPLY WITH THE ESSENTIAL SAFETY REQUIREMENTS.
9. THE USER MUST CONDUCT A RISK ASSESSMENT, AND IMPLEMENT WHATEVER EXTRA SAFETY MEASURES ARE REQUIRED, TO ENSURE THAT THE RESULTANT SYSTEM COMPLIES WITH THE LOW VOLTAGE DIRECTIVE, AND ANY OTHER LEGISLATION IN FORCE AT THE INSTALLATION SITE.

OPEN/CLOSE by limit switching

SWITCH	CLOSED	← INTERMEDIATE →	OPEN
CTS	4-5		
	6-7		
	8-9		
OTS	10-11		
	12-13		
	14-15		
OLS	16-17		
	18-19		
BLK	24-25		

OPEN by limit switching/CLOSE by torque switching

SWITCH	CLOSED	← INTERMEDIATE →	OPEN
CTS	4-5		
	6-7		
	8-9		
OTS	10-11		
	12-13		
	14-15		
OLS	16-17		
	18-19		
BLK	24-25		

ISSUE	DATE	ISSUE	DATE
1	FIRST RELEASE	31-10-17	
2	MODIFY SHEET 2 NOTES 5 (3A BY 0.25A)	06-10-20	

SHEET 2/2	DATE	SIGN.	WIRING DRAWING WD CK-CKR STD, MSM, 1PH, NOCP, HT115, LIM, TOR, NOIMP	This drawing and the information it contains are property of Rotork Controls Limited, and they will not be reproduced or disclosed, in whole or in part, without the prior written consent of Rotork.
MADE BY	31-10-2017	JB		
CHECKED	31-10-2017	JP		
APPROVED	31/10/2017	JP		

	FORMAT	DRAWING 1P
	A4	M103000X - 2